

GEG 50 ES

Dimensions

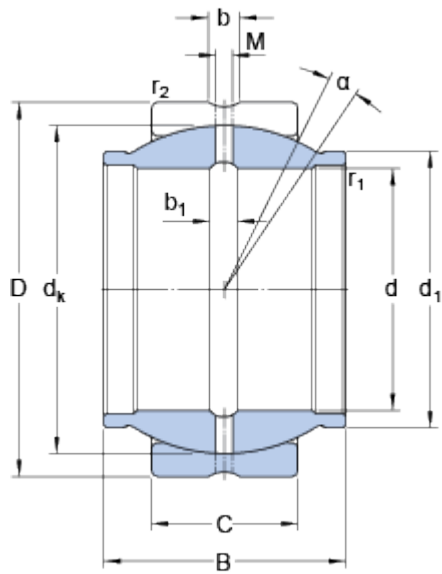

d		50	mm
D		75	mm
B		50	mm
C		28	mm
α		4	°
d_k		66	mm
d_1	≈	57	mm
b		4.6	mm
b_1		4.6	mm
M		3	mm
r_1	min.	0.6	mm
r_2	min.	1	mm

Abutment dimensions

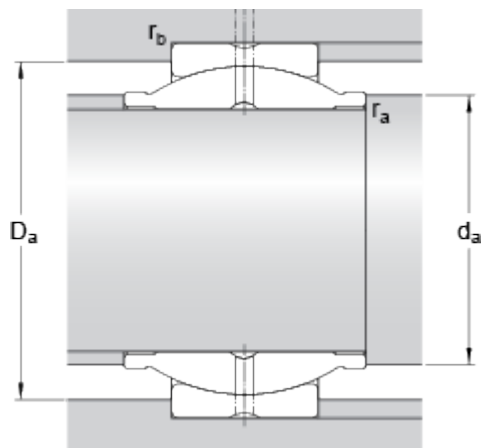

d_a	min.	55.9	mm
d_a	max.	57	mm
D_a	min.	62.7	mm
D_a	max.	70.5	mm
r_a	max.	0.6	mm
r_b	max.	1	mm

Calculation data

Basic dynamic load rating	C	156	kN
Basic static load rating	C_0	780	kN
Specific dynamic load factor	K	100	N/mm ²
Specific static load factor	K_0	500	N/mm ²
Material constant	K_M	330	

Mass

